



FMI (Year 1) – Work-Energy Principle Exam Questions (Edexcel)

Q1.

A block of mass 10 kg is pulled along a straight horizontal road by a constant horizontal force of magnitude 70 N in the direction of the road. The block moves in a straight line passing through two points A and B on the road, where $AB = 50$ m. The block is modelled as a particle and the road is modelled as a rough plane. The coefficient of friction between the block and the road is $\frac{4}{7}$.

(a) Calculate the work done against friction in moving the block from A to B .

(4)

The block passes through A with a speed of 2 m s^{-1} .

(b) Find the speed of the block at B .

(4)

(Total 8 marks)
(Q03 6678/01, Jan 2009)

Q2.

A ball of mass 0.2 kg is projected vertically upwards from a point O with speed 20 m s^{-1} . The non-gravitational resistance acting on the ball is modelled as a force of constant magnitude 1.24 N and the ball is modelled as a particle. Find, using the work-energy principle, the speed of the ball when it first reaches the point which is 8 m vertically above O .

(6)

(Total 6 marks)

(Q03 6678/01/R, June 2013)

Q3.

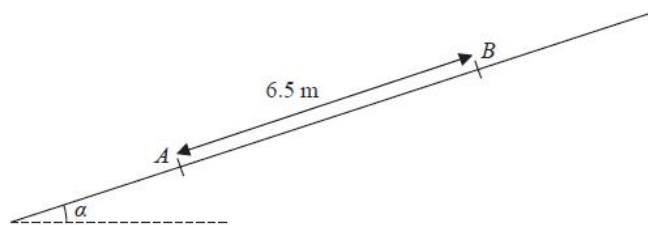

Figure 2

A particle P of mass 10 kg is projected from a point A up a line of greatest slope AB of a fixed rough plane. The plane is inclined at angle α to the horizontal, where $\tan \alpha = \frac{5}{12}$ and $AB = 6.5$ m, as shown in Figure 2. The coefficient of friction between P and the plane is μ . The work done against friction as P moves from A to B is 245 J.

(a) Find the value of μ .

(5)

The particle is projected from A with speed 11.5 m s^{-1} . By using the work-energy principle,

(b) find the speed of the particle as it passes through B .

(4)

(Total for question = 9 marks)
(Q03 6678/01, June 2015)



Q4.

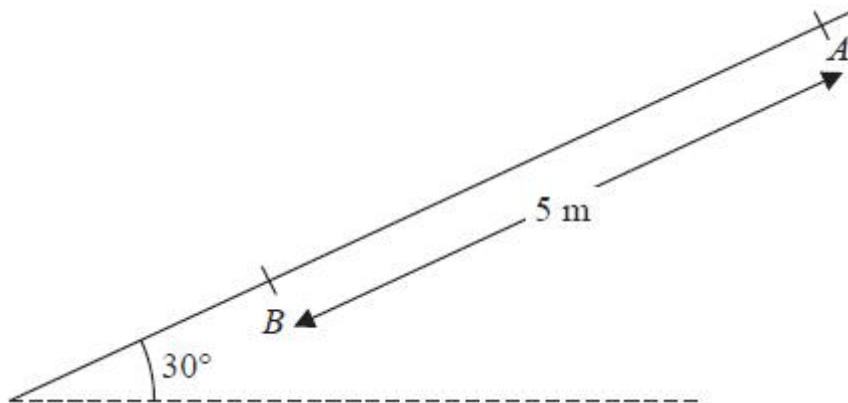

A particle P of mass 2 kg is released from rest at a point A on a rough inclined plane and slides down a line of greatest slope. The plane is inclined at 30° to the horizontal. The point B is 5 m from A on the line of greatest slope through A , as shown in the diagram.

(a) Find the potential energy lost by P as it moves from A to B .

(2)

The speed of P as it reaches B is 4 m s^{-1} .

(b) (i) Use the work-energy principle to find the magnitude of the constant frictional force acting on P as it moves from A to B .

(ii) Find the coefficient of friction between P and the plane.

(7)

The particle P is now placed at A and projected down the plane towards B with speed 3 m s^{-1} . Given that the frictional force remains constant,

(c) find the speed of P as it reaches B .

(4)

(Total 13 marks)

(Q02 6678/01/R, June 2014)

Q5.

A particle P of mass 0.5 kg is projected from a point A up a line of greatest slope AB of a fixed plane. The plane is inclined at 30° to the horizontal and $AB = 2\text{ m}$ with B above A , as shown in Figure 2. The particle P passes through B with speed 5 m s^{-1} . The plane is smooth from A to B .

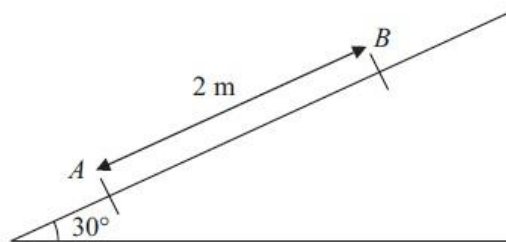

Figure 2

(a) Find the speed of projection.

(4)

The particle P comes to instantaneous rest at the point C on the plane, where C is above B and $BC = 1.5\text{ m}$. From B to C the plane is rough and the coefficient of friction between P and the plane is

μ .

By using the work-energy principle,

(b) find the value of μ .

(6)

(Total 10 marks)

(Q04 6678/01, June 2011)



Q6.

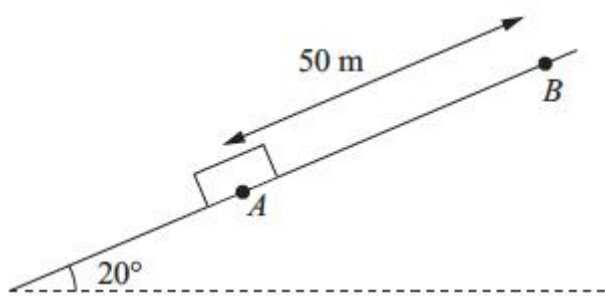

Figure 1

A box of mass 30 kg is held at rest at point A on a rough inclined plane. The plane is inclined at 20° to the horizontal. Point B is 50 m from A up a line of greatest slope of the plane, as shown in Figure 1. The box is dragged from A to B by a force acting parallel to AB and then held at rest at B . The coefficient of friction between the box and the plane is $\frac{1}{4}$. Friction is the only non-gravitational resistive force acting on the box. Modelling the box as a particle,

(a) find the work done in dragging the box from A to B .

(6)

The box is released from rest at the point B and slides down the slope. Using the work-energy principle, or otherwise,

(b) find the speed of the box as it reaches A .

(5)

(Total 11 marks)

(Q02 6678/01, Jan 2011)

Q7.

A particle, P , of mass m kg is projected with speed 5 m s^{-1} down a line of greatest slope of

a rough plane. The plane is inclined to the horizontal at an angle α , where $\sin \alpha = \frac{3}{5}$

The total resistance to the motion of P is a force of magnitude $\frac{1}{5} mg$

Use the work-energy principle to find the speed of P at the instant when it has moved a distance 8 m down the plane from the point of projection.

(Total for question = 7 marks)

(Q03 8FM0/25, June 2019)



Q8.

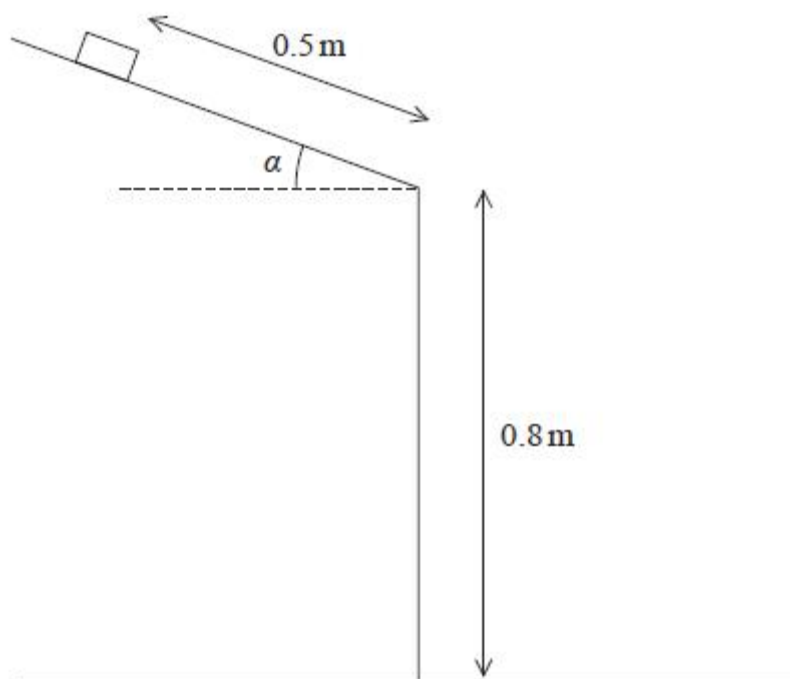

Figure 1

A small book of mass m is held on a rough straight desk lid which is inclined at an angle α to the horizontal, where

$$\tan \alpha = \frac{3}{4}$$

The book is released from rest at a distance of 0.5 m from the edge of the desk lid, as shown in Figure 1.

The book slides down the desk lid and then hits the floor that is 0.8 m below the edge of the desk lid. The coefficient of friction between the book and the desk lid is 0.4

The book is modelled as a particle which, after leaving the desk lid, is assumed to move freely under gravity.

(a) Find, in terms of m and g , the magnitude of the normal reaction on the book as it slides down the desk lid.

(2)

(b) Use the work-energy principle to find the speed of the book as it hits the floor.

(5)

(Total for question = 7 marks)

(Q01 8FM0/25, Oct 2021)



Q9.

A plane is inclined to the horizontal at an angle α , where $\tan \alpha = \frac{3}{4}$

A particle P is held at rest at a point A on the plane.

The particle P is then projected with speed 25 m s^{-1} from A , up a line of greatest slope of the plane.

In an initial model, the plane is modelled as being smooth and air resistance is modelled as being negligible.

Using this model and the principle of conservation of mechanical energy,

- (a) find the speed of P at the instant when it has travelled a distance $\frac{25}{6}$ m up the plane from A . (4)

In a refined model, the plane is now modelled as being rough, with the coefficient of friction between P and the plane

being $\frac{3}{5}$

Air resistance is still modelled as being negligible.

Using this refined model and the work-energy principle,

- (b) find the speed of P at the instant when it has travelled a distance $\frac{25}{6}$ m up the plane from A . (8)

(Total for question = 12 marks)

(Q03 8FM0/25, June 2022)