



Year 1 D1 – Critical Path Analysis Exam Questions (Edexcel)

Q1.

Activity	Immediately preceding activities
<i>A</i>	–
<i>B</i>	–
<i>C</i>	–
<i>D</i>	<i>A, B</i>
<i>E</i>	<i>C</i>
<i>F</i>	<i>A, B</i>
<i>G</i>	<i>A, B</i>
<i>H</i>	<i>E, F</i>
<i>I</i>	<i>D</i>
<i>J</i>	<i>D, G</i>
<i>K</i>	<i>H</i>

(a) Draw the activity network described in the precedence table below, using activity on arc and exactly two dummies. (5)

(b) Explain why each of the two dummies is necessary. (2)

(Total 7 marks)

(Q02 6689/01, June 2014)



Q2.

Activity	Immediately preceding activities
<i>A</i>	–
<i>B</i>	–
<i>C</i>	–
<i>D</i>	<i>A, C</i>
<i>E</i>	<i>B</i>
<i>F</i>	<i>E</i>
<i>G</i>	<i>A</i>
<i>H</i>	<i>D, F</i>
<i>I</i>	<i>D, F</i>
<i>J</i>	<i>H, I</i>

(i) Draw the activity network described in the precedence table below, using activity on arc and the minimum number of dummies.

(ii) Explain why each of your dummies is necessary.

(Total 7 marks)

(Q05 6689/01/R, June 2014)



Q3.

Activity	Immediately preceding activities
A	-
B	-
C	A
D	A
E	A
F	B, C
G	B, C
H	D
I	D, E, F, G
J	D, E, F, G
K	G

(a) Draw the activity network described in the precedence table above, using activity on arc. Your activity network must contain the minimum number of dummies. (5)

Every activity shown in the precedence table has the same duration.

(b) Explain why activity B cannot be critical. (1)

(c) State which other activities are not critical. (1)

(Total for question = 7 marks)

(Q03 8FM0/27, June 2019)



Q4.

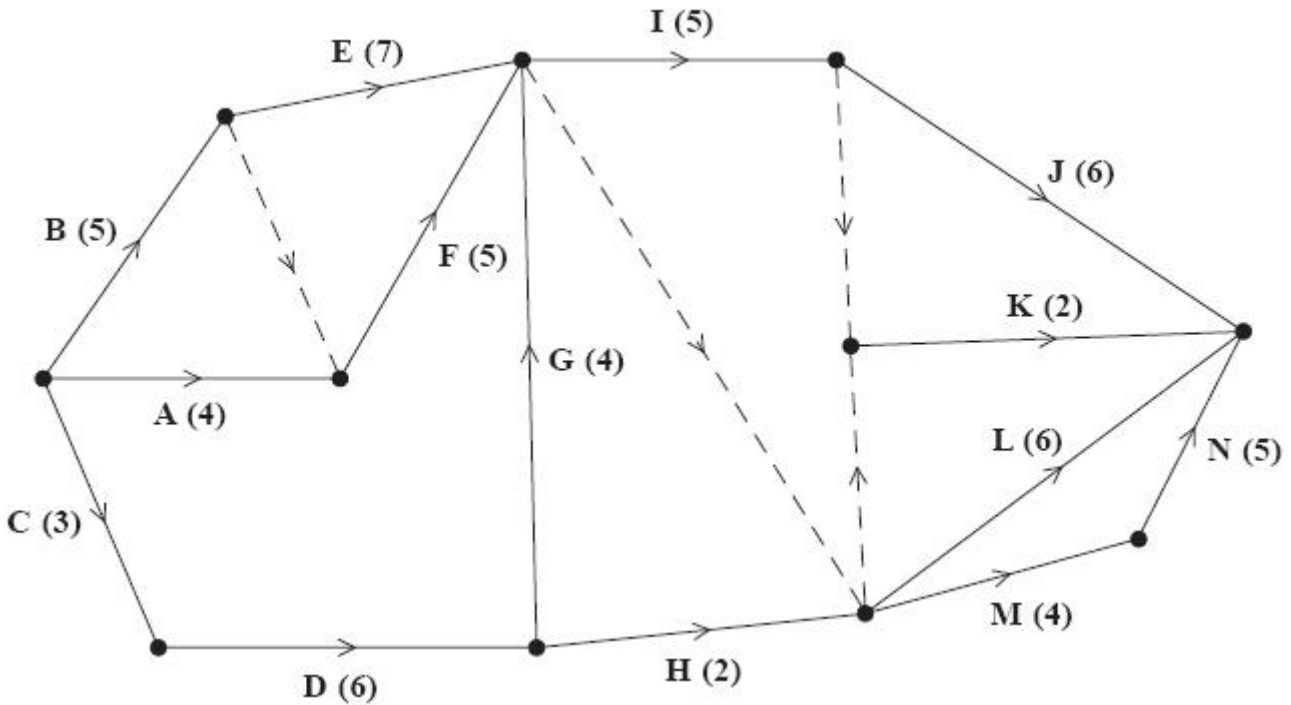

Figure 6

A project is modelled by the activity network shown in Figure 6. The activities are represented by the arcs. The number in brackets on each arc gives the time, in days, to complete the corresponding activity. Each activity requires exactly one worker. The project is to be completed in the shortest possible time.

- (a) Complete Diagram 1 in the answer book to show the early event times and the late event times. (4)
- (b) Draw a Gantt chart for the project on the grid provided in the answer book. (4)
- (c) State the activities that must be happening at time 18.5 (1)

An additional activity, P, is now included in the activity network shown in Figure 6. Activity P is immediately preceded only by activity D. No activity is dependent on the completion of activity P.

Each activity still requires exactly one worker and the revised project is to be completed in the shortest possible time.

- (d) Explain, briefly, whether or not the revised project can be completed in the same time as the original project if the duration of activity P is
 - (i) 10 days
 - (ii) 17 days(2)

(Total for question = 11 marks)

(Q05 6689/01, June 2017)

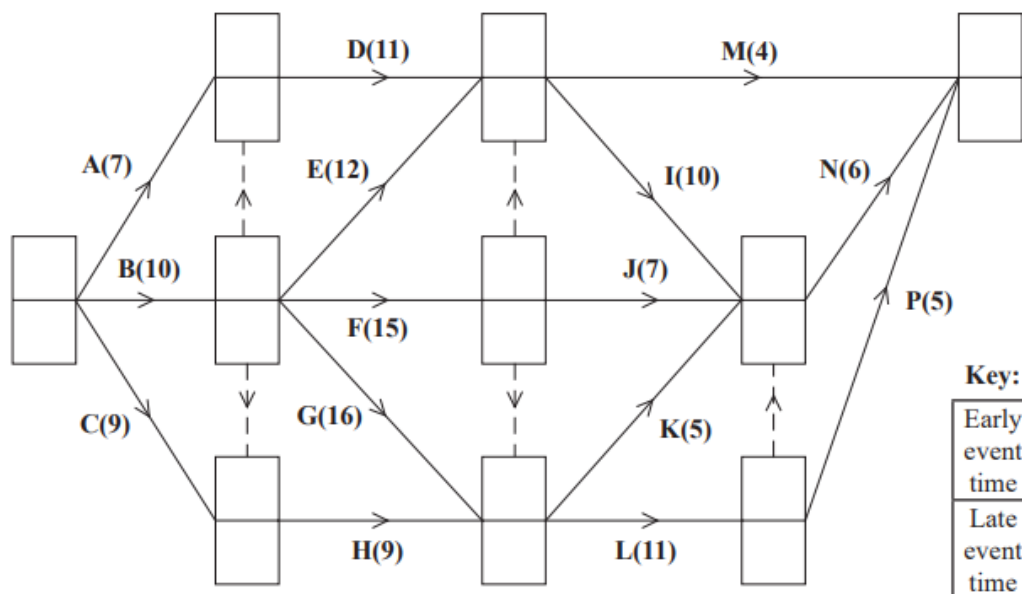
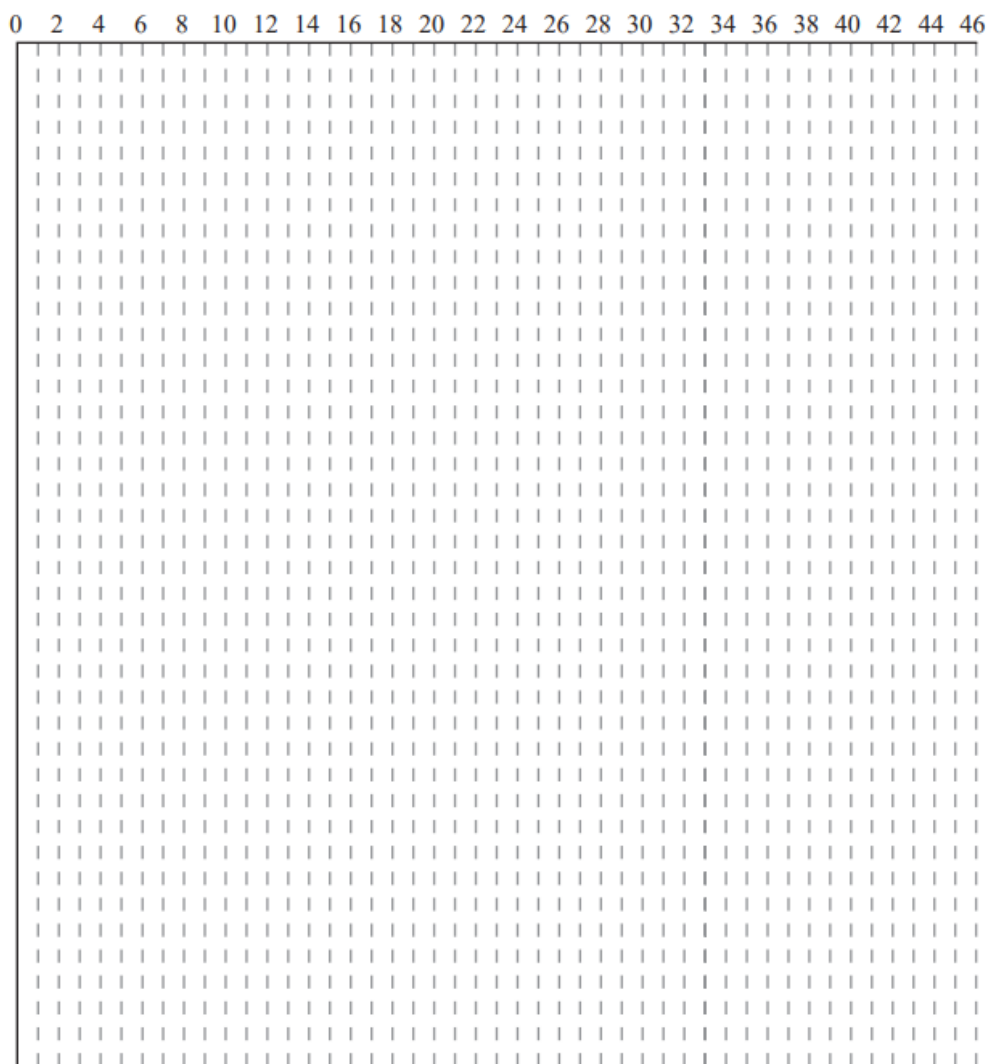

Diagram 1



Grid 1



Q5.

Draw the activity network described in the precedence table below, using activity on arc and exactly three dummies.

(5)

Activity	Immediately preceding activities
A	–
B	–
C	A
D	A
E	B
F	B
G	A, E, F
H	F
I	C
J	D, G
K	D, G

(Total for question = 5 marks)

(Q01 6689/01, June 2016)



Q6.

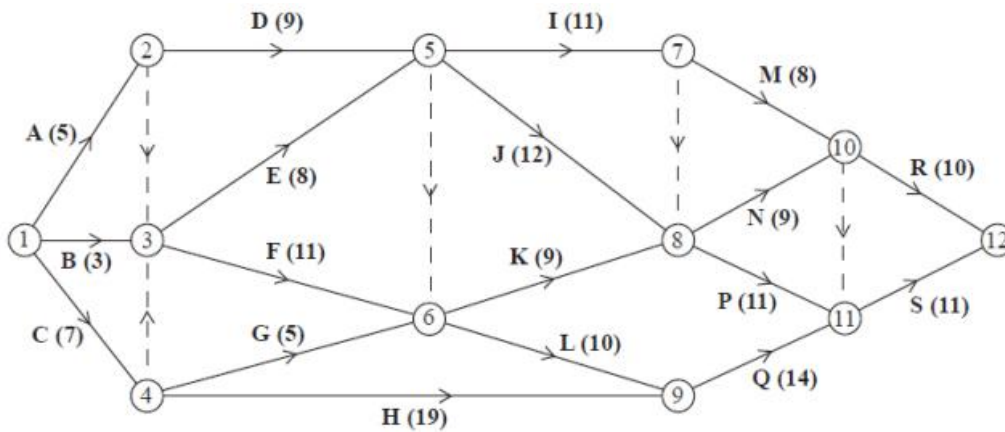

Figure 5

[The sum of the duration of all activities is 172 days]

A project is modelled by the activity network shown in Figure 5. The activities are represented by the arcs. The number in brackets on each arc gives the time, in days, to complete the activity. Each activity requires one worker. The project is to be completed in the shortest possible time.

- (a) Complete Diagram 1 in the answer book to show the early event times and late event times. (4)
- (b) Calculate the total float for activity M. You must make the numbers you use in your calculation clear. (2)
- (c) For each of the situations below, explain the effect that the delay would have on the project completion date.
 - (i) A 2 day delay on the early start of activity P. (2)
 - (ii) A 2 day delay on the early start of activity Q. (2)
- (d) Calculate a lower bound for the number of workers needed to complete the project in the shortest possible time. (1)

Diagram 2 in the answer book shows a partly completed cascade chart for this project.

- (e) Complete the cascade chart. (4)
- (f) Use your cascade chart to determine a second lower bound on the number of workers needed to complete the project in the shortest possible time. You must make specific reference to times and activities. (2)
- (g) State which of the two lower bounds found in (d) and (f) is better. Give a reason for your answer. (2)

(Total 17 marks)
(Q06 6689/01, June 2013)

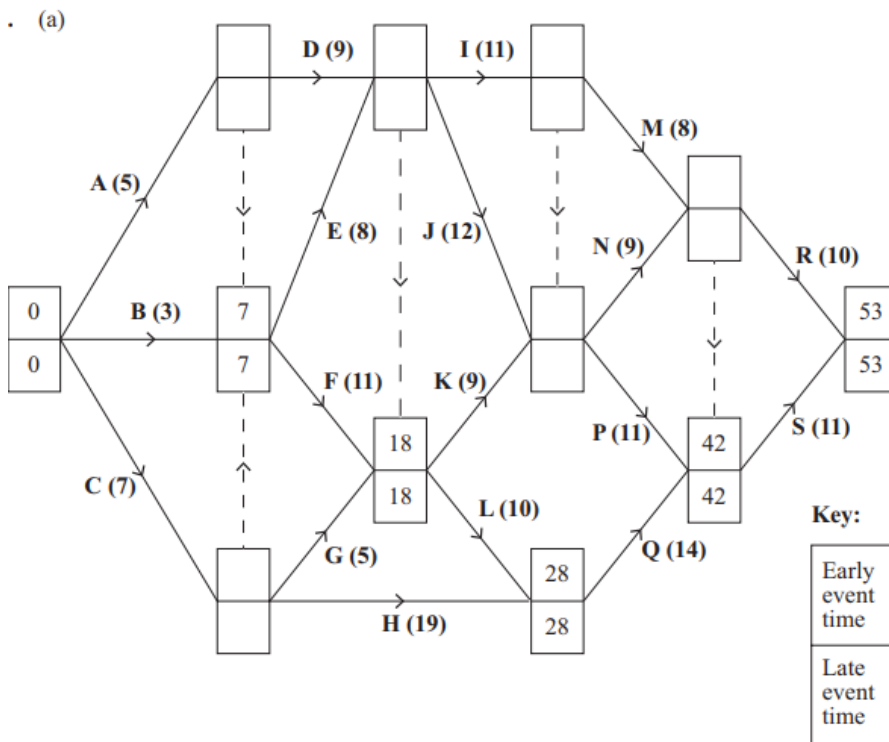

Diagram 1

(e)

■ represents the total float on each activity

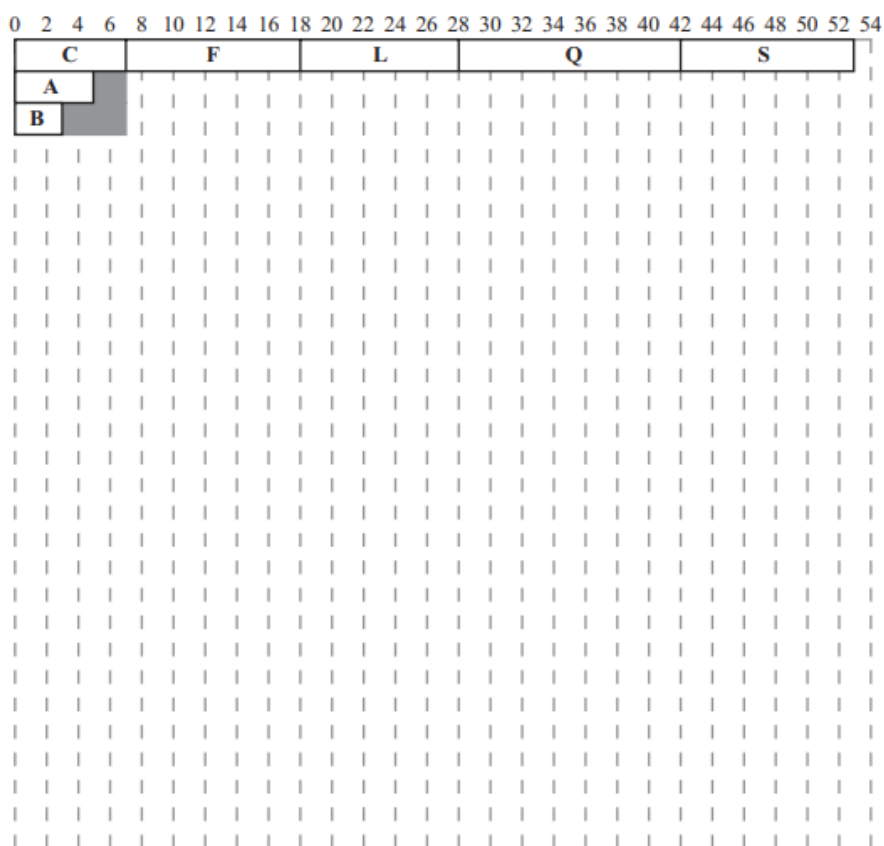

Diagram 2



Q7.

Activity	Immediately preceding activities
A	–
B	–
C	A
D	A
E	B
F	C D
G	D
H	F G
I	H
J	H
K	I J

(a) Draw the activity network described in the precedence table, using activity on arc and exactly two dummies.

(5)

(b) Explain why each of the two dummies is necessary.

(2)

(Total 7 marks)

(Q03 6689/01/R, June 2013)



Q8.

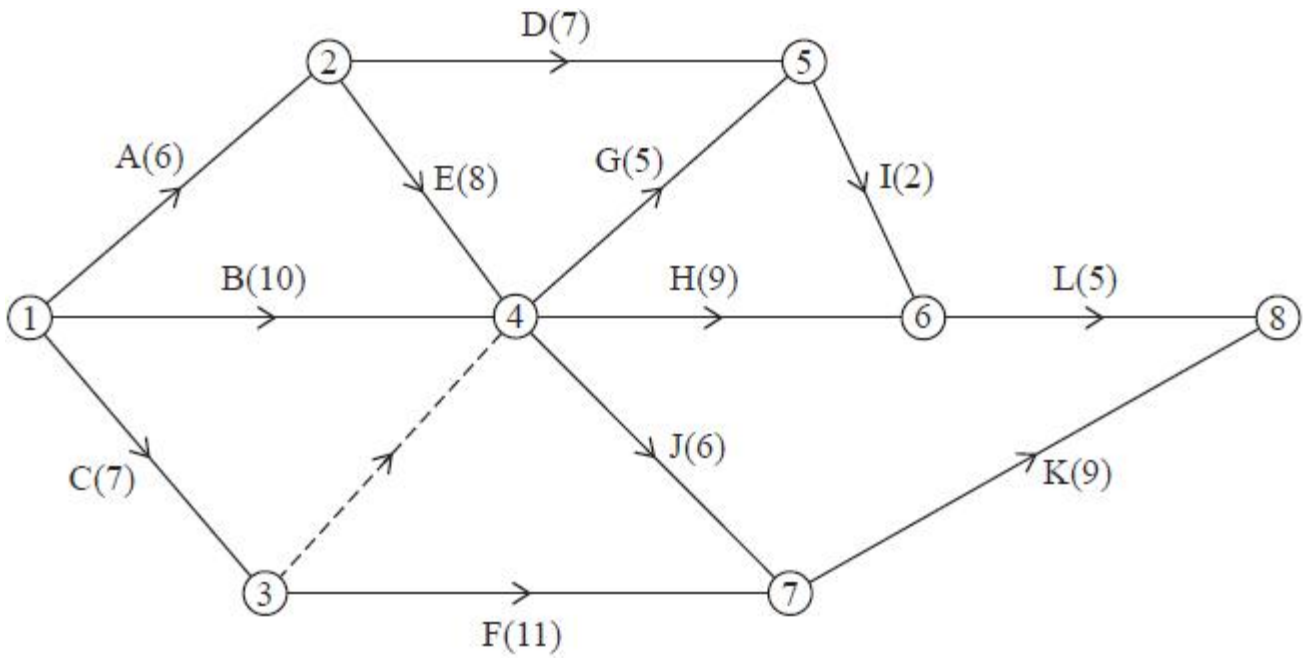

Figure 1

A project is modelled by the activity network shown in Figure 1. The activities are represented by the arcs. The number in brackets on each arc gives the time required, in hours, to complete the corresponding activity. The numbers in circles are the event numbers. Each activity requires one worker, and the project is to be completed in the shortest possible time.

- Explain the significance of the dummy activity from event 3 to event 4. (1)
- Complete Diagram 1 in the answer book to show the early event times and the late event times. (3)
- State the critical activities. (1)
- Calculate a lower bound for the number of workers needed to complete the project in the minimum time. You must show your working. (1)
- Draw a Gantt chart for this project on Grid 1 in the answer book. (4)

(Total for question = 10 marks)

(Q02 8FM0/27, June 2023)



Key:

Early event time
Late event time

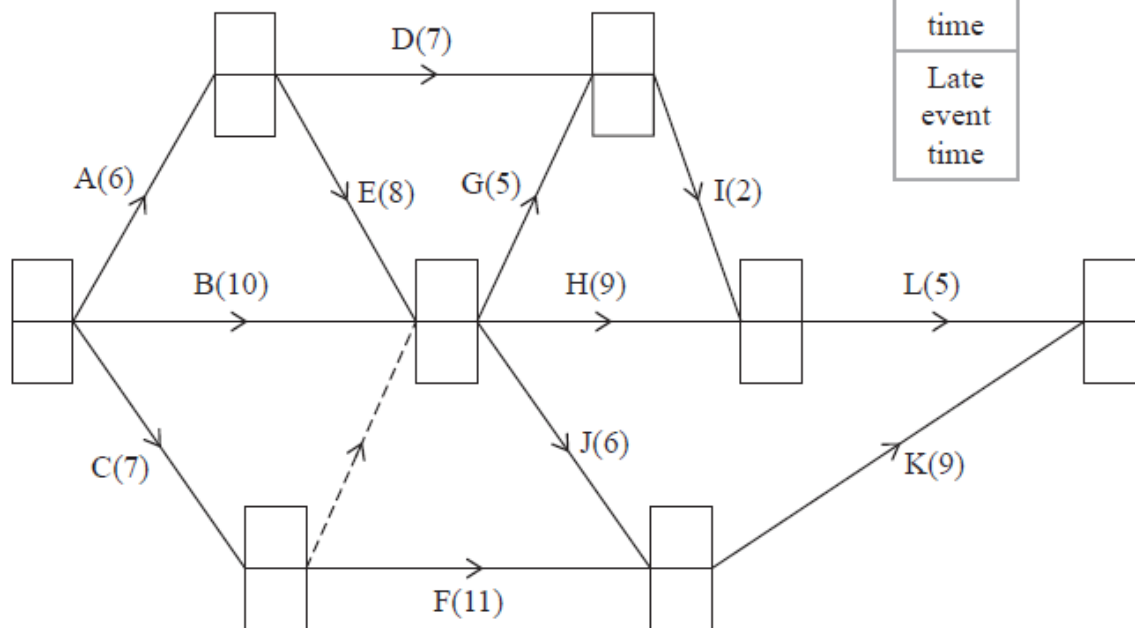
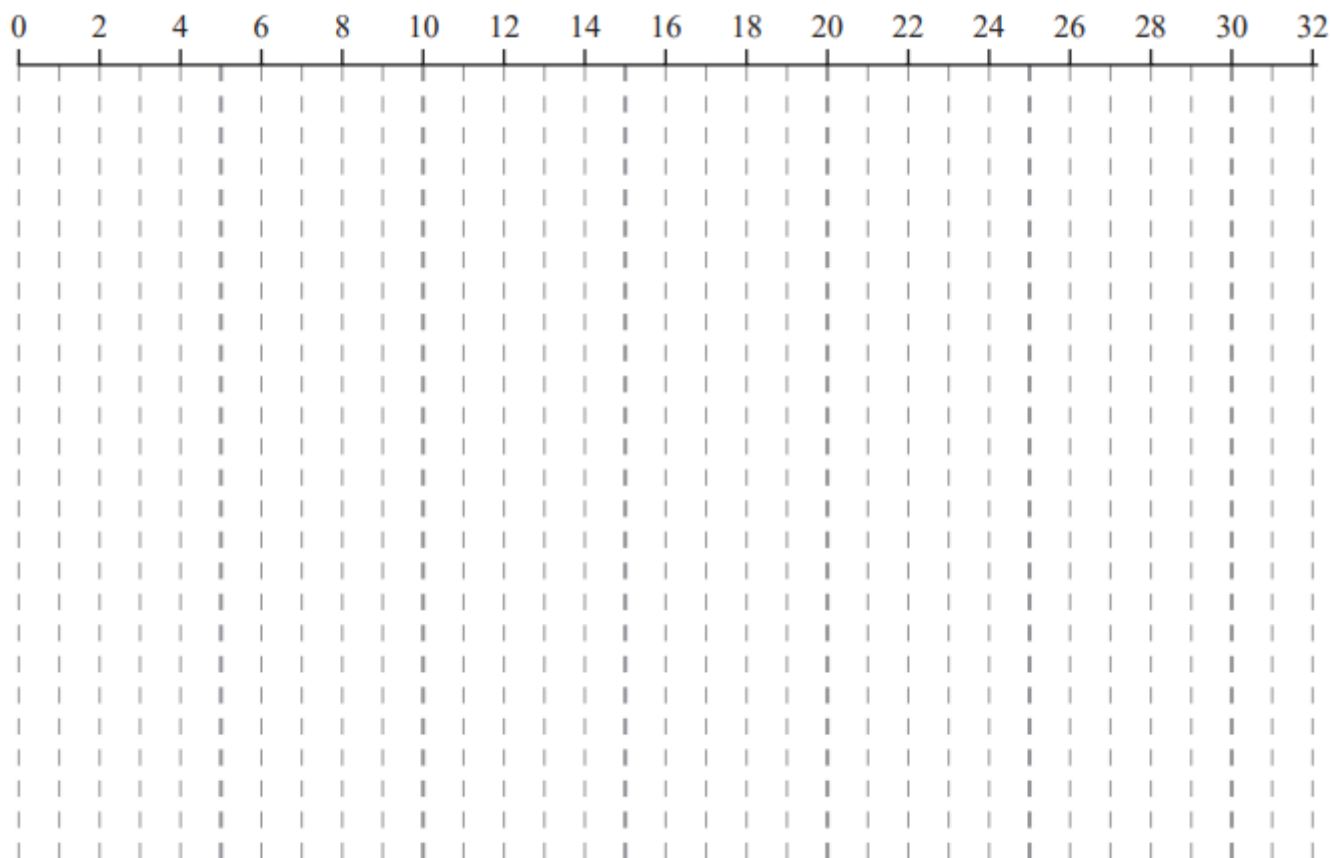

Diagram 1



Grid 1



Q9.

A company manages an awards evening.

The table below lists the activities required to set up the room for the evening, and their immediately preceding activities. Each activity requires exactly one person.

Activity	Immediately preceding activities
A	-
B	A
C	A
D	C
E	C
F	B, D, E
G	E
H	B
J	H, F, G

Figure 1 shows a partially completed activity network used to model the project. Each activity is represented by an arc.

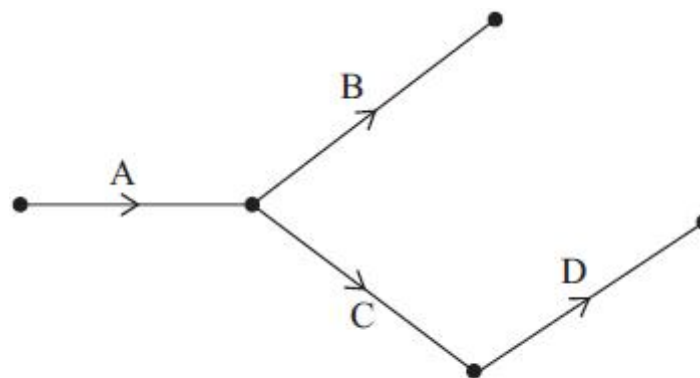

Figure 1

(a) Add the remaining five activities to Diagram 1 in the answer book to complete the activity network, using exactly two dummies.

(3)



In addition to setting up the room, the company must prepare the meals for the guests. Figure 2 shows the activity network for preparing the main courses. The numbers in brackets represent the time, in minutes, to complete each task.

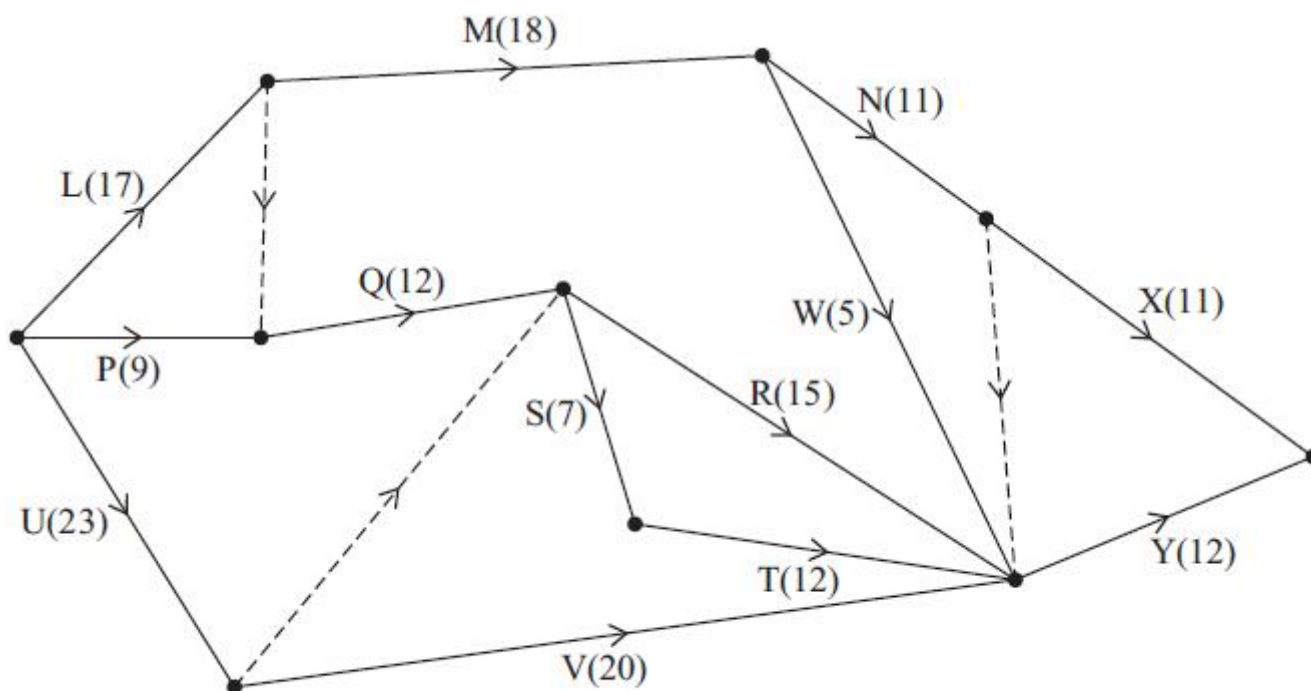

Figure 2

(b) Complete Diagram 2 in the answer book to show the early event times and the late event times for the activity network shown in Figure 2.

(3)

(c) State the critical activities.

(1)

(d) Given that the main courses need to be ready to be served (with all activities completed) at 8 pm, state the latest time that activity R can start.

(1)

(Total for question = 8 marks)

(Q02 8FM0/27, June 2024)

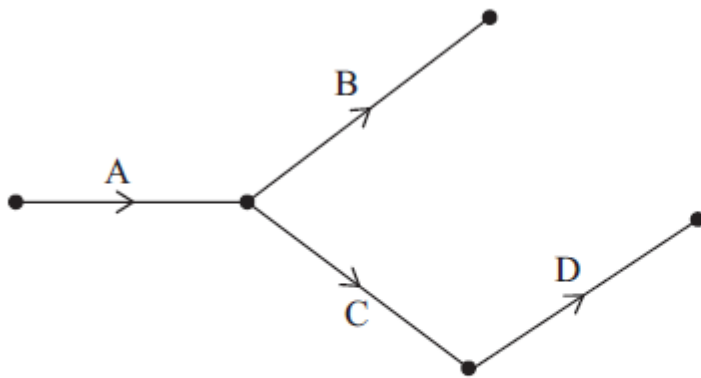
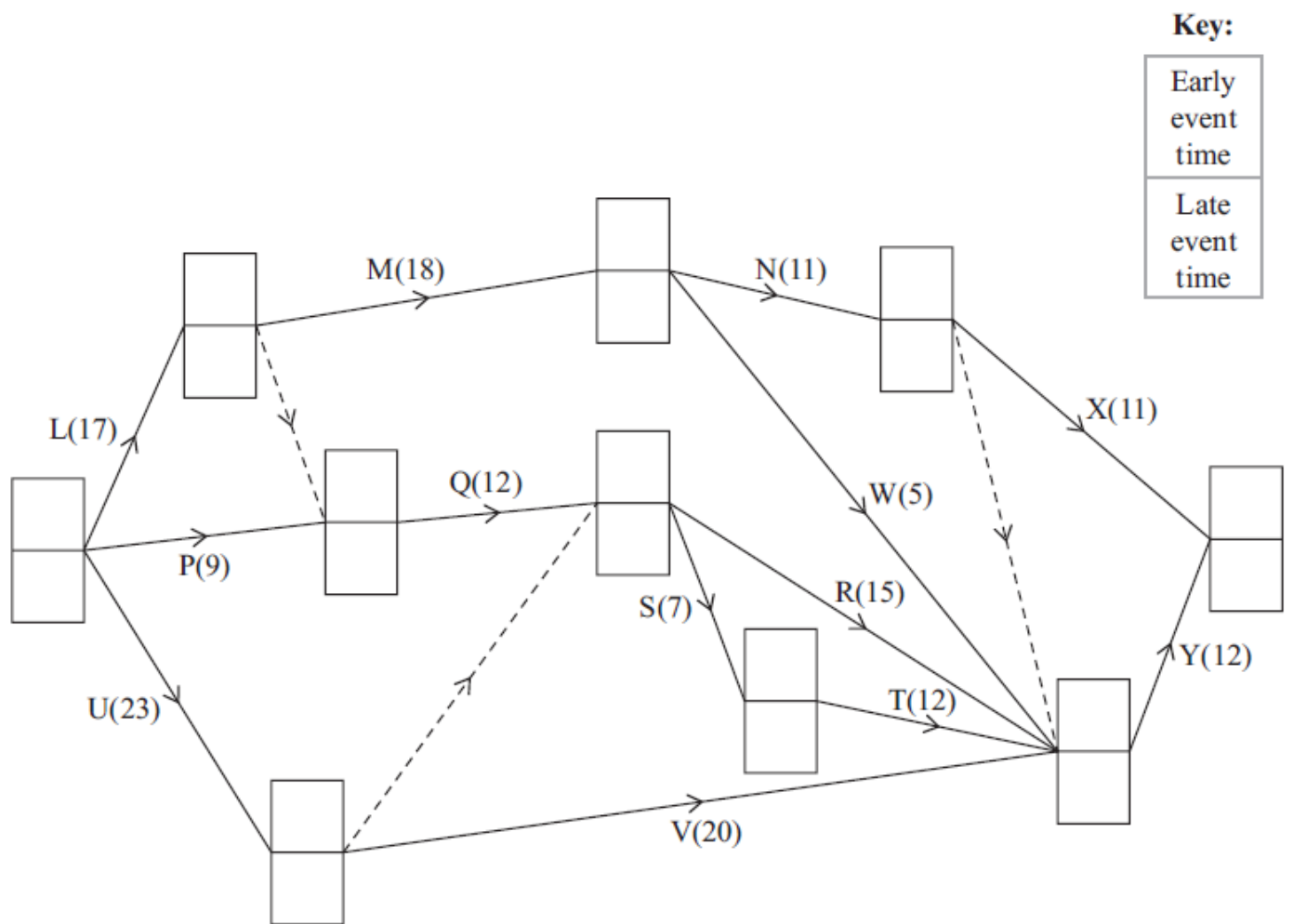

Diagram 1



Key:

Early event time
Late event time

Diagram 2



Q10.

Activity	Time taken (days)	Immediately preceding activities
A	5	-
B	7	-
C	3	-
D	4	A, B
E	4	D
F	2	B
G	4	B
H	5	C, G
I	10	C, G

The table above shows the activities required for the completion of a building project. For each activity, the table shows the time taken in days to complete the activity and the immediately preceding activities. Each activity requires one worker. The project is to be completed in the shortest possible time.

(a) Draw the activity network described in the table, using activity on arc. Your activity network must contain the minimum number of dummies only.

(3)

(b) i) Show that the project can be completed in 21 days, showing your working.

ii) Identify the critical activities.

(4)

(Total for question = 7 marks)

(Q03 8FM0/2K/sA, Specimen papers)